

[CONTRIBUTION FROM THE DEPARTMENT OF CHEMISTRY OF THE GEORGE WASHINGTON UNIVERSITY AND THE GATES AND CRELLIN LABORATORIES OF CHEMISTRY, CALIFORNIA INSTITUTE OF TECHNOLOGY, No. 1242]

The Photochemical Iodine-Sensitized *cis-trans* Isomerization of Dichloroethylene

By ROSCOE G. DICKINSON,¹ RICHARD F. WALLIS² AND REUBEN E. WOOD³

The kinetics of a number of *cis-trans* isomerization reactions occurring in the presence of iodine can be interpreted in terms of a mechanism involving catalysis by iodine atoms.⁴ We have studied the photochemical iodine-sensitized isomerization of *cis-* and *trans*-dichloroethylene and find that the kinetics of this reaction are compatible with such a mechanism.

Acknowledgment.—This study was begun and pursued by Dickinson and Wood during the academic year 1939–1940. The experiments made at that time were rate measurements on the above-named reaction carried out in decalin solutions. Fairly consistent results were obtained for specific rate constants and their temperature coefficients, and kinetics in agreement with those reported in this paper were indicated. However, side reactions involving the iodine occurred appreciably in the experiments in decalin solutions, as shown by decreases in concentration of free iodine during the runs; the results of those experiments could not, therefore, be interpreted in terms of the kinetics of the isomerization reaction so precisely and straightforwardly as should be possible with experiments involving no considerable side reactions.

During the academic year 1947–1948 new experiments were carried out the description and results of which are presented in this paper. The other two authors take responsibility for this publication but we have taken the liberty to include Professor Dickinson's name with ours in recognition of his proposal of and important contributions to this research.

Experimental Details

Apparatus.—The work mentioned above showed that temperatures above 100° would be required to obtain convenient photochemical isomerization rates even with intense illumination. It also showed that the available intensity of illumination would have to be high in order to permit adequate exploration of temperature coefficients of

(1) See acknowledgment.

(2) Present address: Department of Chemistry, Catholic University of America, Washington 17, D. C.

(3) Department of Chemistry, George Washington University, Washington 6, D. C.

(4) (a) The photochemical iodine-sensitized isomerization of *cis-* into *trans*-cinnamic acid: A. Berthoud and Ch. Urech, *J. chim. phys.*, **27**, 291 (1930). (b) The thermal iodine-catalyzed isomerization of *cis-* into *trans*-cinnamic acid: R. G. Dickinson and H. Lotzkar, *This Journal*, **59**, 472 (1937). (c) The thermal iodine-catalyzed isomerization of *cis-* and *trans*-dichloroethylene: R. E. Wood and R. G. Dickinson, *ibid.*, **61**, 3259 (1939). (d) The thermal iodine-catalyzed isomerization of *cis-* and *trans*-dibromoethylene: R. M. Noyes and R. G. Dickinson, *ibid.*, **65**, 1427 (1943). (e) A study of isomerization and exchange reactions in solutions of *cis-* and *trans*-diiodoethylene containing radioactive iodine, both in the presence and absence of illumination: R. M. Noyes, R. G. Dickinson and V. Schomaker, *ibid.*, **67**, 1319 (1945).

rate constants and the effect of reduced light intensity, while operating in a temperature range below that at which thermal isomerization would be a factor seriously complicating the interpretation of the data. These two facts led to the choice of the radial illumination system⁵ shown in Figs. 1 and 2. In this apparatus a cylindrical light source and a cylindrical reaction vessel are placed with axes at the conjugate foci of an elliptical reflector.

The light source selected was a 400-watt type A-H-1 mercury vapor lamp manufactured by the General Electric Company. This lamp has a convenient cylindrical shape and emits an intense light with the maximum of the spectral distribution curve located in the green. It has a glass envelope and emits practically no radiation of wavelengths shorter than 3200 Å. The mercury vapor pressure is a little over 1 atm. when the lamp is operating at full intensity, the arc appearing to be an almost white, pencil-like beam about 16 cm. long.

Although the lamp is designed for operation in open air, it was found necessary to have a light filter solution flowing around the lamp. This change in operating conditions did not, however, affect its performance materially. A pyrex glass tube about 8 cm. in diameter was placed around the lamp and held in position by rubber stoppers cut to size. Outlet and inlet tubes for the light filter solution were placed in the top and bottom stoppers, respectively. Cooling of the filter solution was effected by forcing it through a spiral condenser by means of an all-glass centrifugal pump. A thermometer was placed in the line so that the temperature of the filter solution leaving the lamp could be observed. The speed of the motor driving the pump was always adjusted so that the temperature shown by this thermometer remained at 68 ± 5°. This was done because the absorption spectrum of the filter is somewhat temperature dependent.

The elliptical reflector consisted of side, top, and bottom pieces made of chromium-plated brass. The side piece was bent into an elliptical shape and held in position by three brass templates. The top and bottom pieces were bolted to the upper and lower templates. The reflector was disassembled and dusted from time to time during the course of the research. No evidence of dulling or tarnishing appeared.

A brass tube directed toward the lamp was soldered into the wall of the reflector. An RCA Type 922 vacuum photocell was mounted in a light-tight box attached to the end of this brass tube. The photocell was connected in series with a 22.5-volt "B" battery and a microammeter (a suitably shunted and calibrated galvanometer was used in the experiments at reduced light intensity). The stated characteristics of this photocell and the light intensities involved were such that the current through the circuit should have been and is assumed to have been directly proportional to the light intensity. This system was used to observe the constancy of light intensity during runs and to evaluate the relative intensities in the various runs. Reduced intensities were obtained by wrapping a piece of blackened Monel metal wire cloth around the jacket of the lamp. Wire cloth screens of two different coarsenesses were used.

In "blank" runs, solutions of dichloroethylene containing no iodine were illuminated without filtration of the light other than that effected by the glass in the light path. A change in dielectric constant of the solutions equivalent to significant amounts of isomerization was observed in these runs. A light filter which would prevent photo-

(5) W. A. Noyes, Jr., and P. A. Leighton, "The Photochemistry of Gases," Reinhold Publishing Corporation, New York, N. Y., 1941. p. 25.

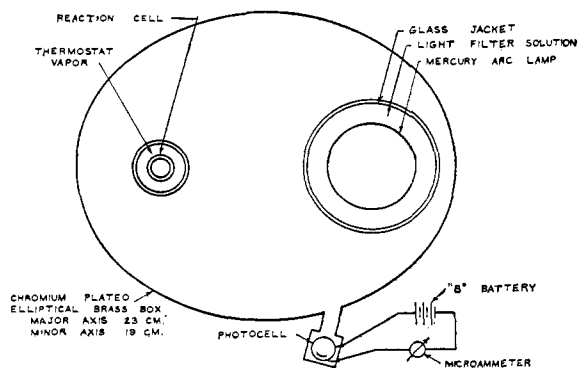

Fig. 1.—Horizontal section through illumination apparatus.

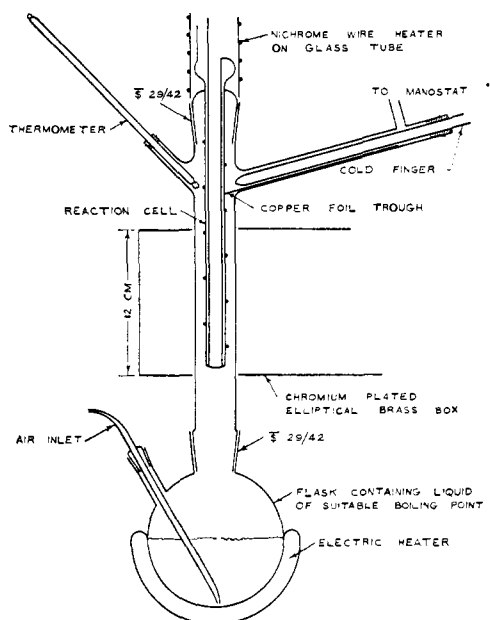

Fig. 2.—Vapor thermostat and reaction cell.

chemical reaction in the absence of iodine was sought and found. It is an aqueous solution of $1/2$ formula weight of cupric chloride and 1 formula weight of calcium chloride per liter of solution. Incidentally, a cupric sulfate solution was unsatisfactory; these two solutions differ significantly in absorption spectrum only in that the chloride solution absorbs more strongly in the violet and near-ultraviolet. *cis-* and *trans-*dichloroethylene and their benzene solutions were shown by means of a Beckman ultraviolet spectrophotometer to absorb weakly in the 3200 to 3700 Å. range.

The reaction cell is shown in Figs. 2 and 3. The high vapor pressures of the reaction solutions and the necessity for continuous measurement of their temperatures were principal factors influencing the design of the cell. Preliminary tests demonstrated that the cell, which was constructed of Pyrex glass tubing, could withstand an internal pressure of at least 8 atm. From a theoretical standpoint it was advantageous to have the solution in the form of a thin cylindrical lamina with axis passing through the focus of the elliptical reflector. A sheet of bright aluminum foil was wrapped around the thermometer as shown in Fig. 3 so that no radiation would fall directly on the thermometer and so that the light paths would represent as much vertical symmetry as possible.

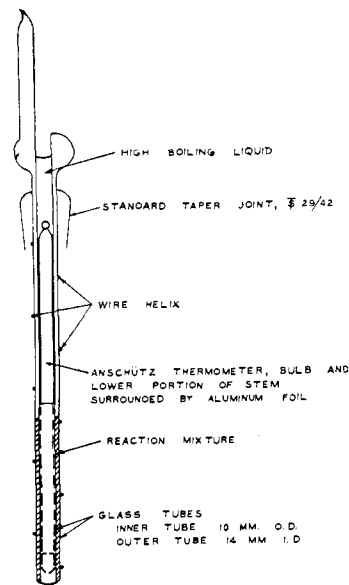

Fig. 3.—Reaction cell.

The method of thermostating the reaction solution is shown in Fig. 3. Because the cell was heated appreciably by the radiation focused on it, it was necessary to direct a flow of condensate over the outside of the cell by means of a copper foil trough and a wire helix wound on the cell. The condensate flowed smoothly over the glass; it seems probable that any inconstancy of light paths caused by irregularities of flow had a negligible effect on the rate measurement. The desired temperatures were obtained and maintained by suitable choice of the boiling liquid and by adjustment of the manostat controlling the boiling pressure. The temperature at the center of the reaction cell was measured by an Anschütz thermometer and was maintained constant within $\pm 0.2^\circ$ during an experiment. The thermometer was immersed in decalin to ensure good thermal conduction to the inner wall of the reaction cell. The thermometer was calibrated at 100, 110 and 118° with boiling water, toluene, and acetic acid, respectively.

The temperature at the center of the reaction cell was consistently 4 or 5° higher than that of the thermostat vapor. This difference doubtless represents in part thermal gradients across the two cell walls and intervening solution, in part superheating of the condensate flowing over the outer wall. The thermal gradient across the inner wall would be expected to be smaller than that across the outer wall; it would be zero if all the radiation were absorbed before reaching the inner wall, neglecting heat conduction vertically through the inner wall to outside the illuminated zone. The thermal gradient in the bulk of the reaction solution, too, is probably small because of convection currents. So, in tabulations and calculations, we have treated the temperatures measured at the center of the reaction cell as the temperatures of the reaction solutions. We estimate the temperature uncertainties as follows: the true solution temperatures corresponding to calculated rate constants are not greater than, and are not more than 1° less than those recorded; the true differences in temperatures between runs, the basis of the activation energy calculation, are within a few tenths of a degree of those indicated by the recorded data.

To prevent the reaction mixture from refluxing from the upper part of the reaction vessel (outside the thermostat), this part of the reaction vessel was heated a little above the temperature of the thermostat by an electric heating coil wound on a slip-over glass tube. No condensate or iodine vapor was visible in this part of the reaction vessel once thermal equilibrium had been established. The portion of the reaction vessel extending above the reflecting

box was shielded from the direct rays of the lamp. Wood and Stevenson⁶ obtained evidence that the rate of the thermal isomerization of the 1,2-dichloroethylenes catalyzed by iodine in the vapor phase is of the same order of magnitude as the rate in liquid solutions when comparable concentrations are used. From the foregoing considerations we believe that the isomerization in the vapor phase in this work was negligible.

As in previous work on the isomerization of the 1,2-dihaloethylenes,^{40,d,e} the analytical method was based on the difference in dielectric constant between the *cis* and *trans* isomer. The heterodyne circuit employed to measure dielectric constants was similar to that described by Hudson and Hobbs⁷ and was operated at 1.7 megacycles. The liquid dielectric condenser (dielectric cell) is shown in Fig. 4. The amount of solution required to fill it was somewhat less than the 5 ml. used in the photo-chemical reaction cell. The gold-plated brass tubes were soldered to the glass members by applying a platinum film to the glass with a platinizing solution which is described by Strong.⁸ The platinum chloride required was prepared by heating chloroplatinic acid at 110° until no more vapors were evolved. Water from a thermostat maintained at 24.7° was circulated around the dielectric cell while measurements were being made.

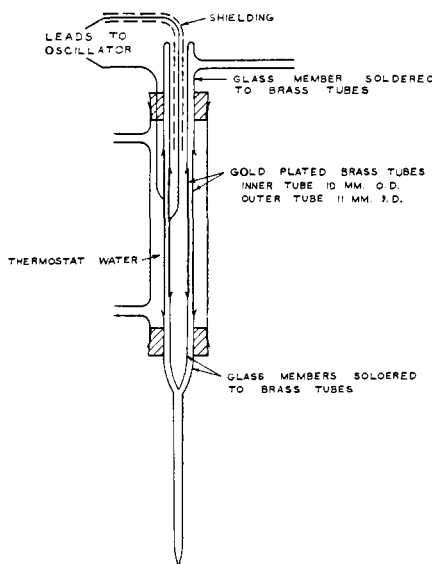

Fig. 4.—Dielectric cell.

Chemical.—It seemed desirable in the photochemical experiments to use one of the solvents which had been used in the thermal experiments.⁴⁰ Decalin was tried first because its relatively low vapor pressure at convenient reaction temperatures would permit the use of flat-windowed photochemical reaction cells of conventional design. However, the earlier experiments as well as some carried out since this research was resumed indicate that in the decalin solutions there is a slow but appreciable side reaction. This may be a photochemical reaction between iodine and decalin itself or between iodine and impurities in the decalin which are not removed by reasonably careful purification.

Decalin was therefore abandoned and benzene was used as the solvent in all the isomerization experiments tabulated below. This more volatile solvent was permissible

(6) R. E. Wood and D. P. Stevenson, *THIS JOURNAL*, **63**, 1650 (1941).

(7) B. E. Hudson, Jr., and M. E. Hobbs, *Rev. Sci. Instruments*, **13**, 140 (1942).

(8) J. Strong, "Procedures in Experimental Physics," Prentice-Hall, Inc., New York, N. Y., 1938, p. 152.

in the tubular reaction cell. Eastman Kodak Co. "White Label" benzene was cooled while being stirred, until about half frozen. The remaining liquid was poured off and discarded. The solid benzene thus obtained had a melting point of 5.5°. It was dried over anhydrous calcium chloride and distilled in an apparatus from which moisture was excluded. The solvent so prepared did not react with iodine under conditions corresponding to those of the isomerization experiments. The only evidence of any side reaction in the runs represented by the quantitative data reported here was the occasional appearance of a small ring of brownish coloration on the reaction vessel where the reaction solution meniscus had been.

cis- and *trans*-dichloroethylenes were obtained in 90–95% purity from the Columbia Organic Chemicals Company, and from the Westvaco Chlorine Products Company. The liquids were distilled through a packed column under an atmosphere of dry carbon dioxide. The boiling ranges of the final products were less than 0.1°. Exactly 10.00 mole per cent. solutions of the pure *cis*- and *trans*-dichloroethylenes in benzene were prepared by weighing and were stored under carbon dioxide in closed vessels designed to permit withdrawal of the solution without admission of air.

Merck "Reagent" grade iodine was sublimed from a mixture with Merck "Reagent" grade potassium iodide and was then resublimed. An 0.0602 mole per cent. iodine solution in benzene was prepared.

Procedure.—The following procedures were followed in the majority of the experimental runs; exceptions will be described below. Manipulations involved in filling and sealing the reaction cell were carried out under carbon dioxide to exclude oxygen. Between runs the reaction cell was filled with chromic acid cleaning solution to remove any materials which might influence the reaction. The chromic acid was removed by repeated washing with water and then twice with acetone. The residual solvent was pumped off.

Pure dry carbon dioxide was passed through the cell for a few minutes, after which the cell was stoppered and weighed. In the case of the runs with dilute iodine solutions, a suitable volume of benzene solution of iodine was pipetted into the cell which was then reweighed. Iodine crystals were added directly to the cell for the experiments with concentrated iodine solutions. In either case sufficient solution of one of the dichloroethylenes was next added to make a total of 5 ml. of reaction solution. A final weighing of the reaction cell was made, after which additional carbon dioxide was passed through the upper part of the cell to remove any vapors which might pyrolyze. The stream of carbon dioxide was not permitted to reach down to the reaction solution, however, so no fractionation of the latter is believed to have occurred; the results of blank experiments supported this assumption. The cell was then sealed off. At the start of these operations the mercury vapor lamp and the thermostat heater were turned on so that they would be at operating temperatures by the time everything else was ready to start the run.

The filled and sealed reaction cell was put into place in the apparatus and the starting time noted. Reference marks on both members of the ground glass joint supporting the cell made it possible to orient the cell in exactly the same manner for each run, a precaution which seemed advisable since the axis of the cell and that of the ground glass joint did not exactly coincide. The heater for the vapor portion of the cell was clamped into place. Thermal equilibrium was practically achieved within five minutes. Light intensity readings were taken at fifteen-minute intervals throughout the run. The run was concluded by turning off the light and removing the cell from the thermostat. When the solution had cooled it was transferred to a test-tube containing a clean coil of copper wire to remove iodine: this method of removing iodine had been shown⁴⁰ not to produce isomerization.

After the solution had become free of iodine, its dielectric constant was measured and from it together with the knowledge of the total dichloroethylene concentration the concentrations of *cis*- and *trans*-dichloroethylene in it were

calculated. Such calculations were based on the assumption that, over the concentration ranges used, the dielectric constant is a linear function of the mole fractions of *cis*- and *trans*-dichloroethylene present in the solution. This assumption was tested and found valid for the two-component system comprising solutions of *cis*-dichloroethylene from 7 to 10 mole per cent. in benzene, it was also tested and found valid for the three-component system comprising benzene solutions of *cis*- and *trans*-dichloroethylene in which the total dichloroethylene concentration was kept at 10 mole per cent.

Calculations

The conditions and results of the rate experiments are summarized in Tables I, II and III. The first part of this discussion will attempt to show how the specific rate constants, tabulated in the last column of each table, were calculated from the data, and to indicate how they are related to the interpretation of the results in terms of an iodine atom catalysis. The line of argument will be to derive, on the basis of the proposed mechanism, the equations for certain quantities (k 's) the values of which should be constant or should have a predicted dependence on the experimental parameters if the proposed mechanism is compatible with the data.

The proposed mechanism is⁴

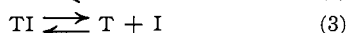
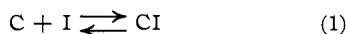

where C and T represent the *cis* and *trans* isomers, respectively, I is atomic iodine, and CI and TI are complexes. On this basis one can write for the over-all reaction

$$-d(C)/dt = k_1(I)(C) - k_2(I)(T) \quad (4)$$

in which k_1 and k_2 are specific rate constants for the forward and reverse *cis* to *trans* isomerization (note that k_1 and k_2 do not refer to reactions 1 and 2 above). This is an expression for the local rate of isomerization. In the case of photochemical experiments the rate will vary from place to place in the solution because of varying light intensity and consequently varying iodine atom concentration (it is assumed that recombination of iodine atoms occurs before they have diffused appreciably). The over-all rate of isomerization will be the average local rate.

Because of the uniformity of C and T concentrations throughout the solution, which it is reasonable to assume because of the slowness of isomerization compared to probable stirring processes, the over-all isomerization rate should be given by

$$-\overline{d(C)}/\overline{dt} = k_1(\overline{I})(C) - k_2(\overline{I})(T) \quad (5)$$

Here $-\overline{d(C)}/\overline{dt}$ represents the over-all net rate of conversion of *trans* to *cis* dichloroethylene, and \overline{I} represents the average concentration of iodine atoms throughout the reaction solution.

If one now considers isomerization experiments of the kind reported here in which \overline{I} remains essentially constant throughout a given experiment

and which start with only the *cis* or only the *trans* isomer, equation (5) can be integrated. Representing by α the fraction of dichloroethylene in the *cis* form at the time t and letting K be the equilibrium constant $(trans)_{eq}/(cis)_{eq}$, the integration leads to the expressions for k_1

$$k_1 = -\frac{K}{i(I)(K+1)} \ln \frac{(K+1)\alpha - 1}{K} \quad (6)$$

which applies to experiments in which the initial dichloroethylene is all *cis*, and

$$k_1 = -\frac{K}{i(I)(K+1)} \ln [1 - (K+1)\alpha] \quad (7)$$

which applies to experiments in which the initial dichloroethylene is all *trans*. k_2 has been eliminated from these equations by $K = k_1/k_2$.

It remains to get expressions for \overline{I} in terms of the experimental parameters. In addition to reactions 1, 2, and 3 one must consider processes by which iodine atoms are produced from molecular iodine and also the recombination of the atoms to form the molecule, *i. e.*

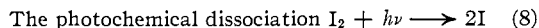

It is understood that energy and momentum requirements may be satisfied by particles not symbolized in these expressions. The usual treatment of rate expressions based on processes 1, 2, 3, 8, 9, and 10 leads to the following implicit expression for \overline{I} , the local steady-state iodine atom concentration

$$\phi i + k_9(I_2) = k_{10}(I)^2 \quad (11)$$

where ϕ is the quantum yield for process 8, i is the local rate of light absorption in einsteins liters⁻¹ seconds⁻¹, and k_9 and k_{10} are the specific rate constants of processes 9 and 10, respectively.

The azimuthal variation of i throughout the reaction vessel will not affect the form of rate expressions to be derived under the assumptions that the light enters and leaves the cell radially and that the isomer concentrations are at all times uniform throughout the solution. Therefore, since quantum yields are not calculated, it is not necessary to consider the azimuthal variation further.

The radial relations follow from applications of Beer's and Lambert's laws. Let r be the distance from the axis of the reaction cell to the point in the solution where the rate of light absorption is i , and let r_0 and r_1 be the distances from the cell axis to the inner and outer boundaries of the solution, respectively. Let ϵ be a molal absorption coefficient of iodine for a particular wave length and let I_0 be the rate at which light enters the outer surface of the solution (in einsteins per second). It can be shown that the rate of light absorption per unit volume in a thin cylindrical shell of solution of radius r is given by

$$i = \frac{I_0}{V} (I_2)\epsilon(r_1 - r_0) [\exp(-\epsilon(I_2)(r_1 - r)) + m \exp(-\epsilon(I_2)(r_1 + r - 2r_0))] \quad (12)$$

In this equation V is the total volume of the reaction solution, m is a fraction which takes account of the loss of light which occurs at the aluminum reflectors. The derivation involves approximations which are good when r_0 is considerably larger than $r_1 - r_0$. These are thought to be satisfactory approximations for the cell used in this work.

A combination of equations 11 and 12 gives

$$(I) = \sqrt{\frac{1}{k_{10}}} \left\{ k_9(I_2) + \phi \left[\frac{I_0}{V} (I_2) \epsilon (r_1 - r_0) \right] \left[\exp(-\epsilon(I_2)(r_1 - r)) + m \exp(-\epsilon(I_2)(r_1 + r_2 - r_0)) \right] \right\} \quad (13)$$

The average value of the iodine atom concentration, (\bar{I}) , is needed to evaluate the specific rate constant, k_1 (equation 7). Thus

$$(\bar{I}) = \frac{1}{r_1 - r_0} \int_{r_0}^{r_1} (I) dr \quad (14)$$

This expression for (\bar{I}) can be integrated for several cases of interest. For the case of purely thermal isomerization I_0 is zero and only the first term under the radical sign in equation 13 remains, in this case $(I) = \sqrt{k_9/k_{10}}[(I_2)]$. On the other hand, the experiments reported here were carried out so that the rate of thermal isomerization should be small compared to the photochemical rate. The approximate evaluation of (\bar{I}) for such experiments is done by neglecting the first (thermal) term in equation 13. In making this evaluation, it is convenient to treat separately two cases: the case in which the iodine concentration is low enough so that only a fairly small fraction of the incident light is absorbed in passing through the reaction solution, and the case in which the iodine concentration is high enough so that most of the light is absorbed in passing through the solution.

In the case of pale solutions in which the absorption of light approaches zero the sum of the exponential terms in equation 13 approaches 1 + m giving

$$(\bar{I}) = (I) = \sqrt{\frac{\phi I_0(I_2)\epsilon}{V} (r_1 - r_0) (1 + m)} \quad (15)$$

When this expression for (\bar{I}) is put into equations 6 and 7 and constants are lumped together, expressions are obtained for k_p , the apparent pale solution photochemical specific rate constant for the *cis* and *trans* isomerization

$$k_p = - \frac{K}{\nu(K+1)\sqrt{I_0(I_2)}} \ln \frac{(K+1)\alpha - 1}{K} \quad (16c)$$

equation 16c applying to experiments starting with *cis* and no *trans* isomer, and

$$k_p = - \frac{K}{\nu(K+1)\sqrt{I_0(I_2)}} \ln [1 - (K+1)\alpha] \quad (16t)$$

equation 16t applying to experiments starting with *trans* and no *cis* isomer. By plotting values of k_p against (I_2) and extrapolating to $(I_2) = 0$ the best value of the true pale-solution photo-

chemical specific rate constant should be obtained. It should be stated that since the thermal and photochemical rates both are proportional to $\sqrt{(I_2)}$ in pale solutions, neglecting the thermal isomerization is as good an approximation for solutions having very small light absorption as for moderately absorbing solutions—a little better, in fact.

Although equations 16 have been derived for the case of monochromatic light, equations of the

same form apply to polychromatic light provided that any variations of the intensity of incident light do not involve variation in the relative intensities of the various light components. Tables I and II show the pale solution results. In these tables the k_p 's are calculated from equations 16 where the I_0 values are in arbitrary units representing relative values as indicated by the photocell output. Most of these specific rate constants are plotted against the iodine concentration in Fig. 5. It can be seen that the k_p 's vary only a little with ten-fold variation in (I_2) and that their variation is in the direction that would be expected, in view of the approximations made in getting equations 16 from equation 13, if the reaction mechanism is indeed a simple iodine atom catalysis.

Equation 13 is also the starting point for the treatment of deep-colored solutions. In this case the second exponential term in that equation approaches zero. Then, still neglecting the thermal term and putting the residue of equation 13 into equation 14 and integrating, one gets

$$(\bar{I}) = \text{constant} \times \sqrt{I_0/(I_2)} \quad (17)$$

On the basis of this equation, the photochemical rate in deep-colored solutions should vary inversely with $\sqrt{(I_2)}$. Since the thermal rate should vary directly with $\sqrt{(I_2)}$, in the very deep-colored solutions the thermal rate can become appreciable compared to the photochemical even though the temperature is such that this is not the case with paler solutions. The exact treatment of cases where both thermally and photochemically produced iodine atoms are present in effective quantities is complicated. However, if one makes the approximation that the photochemical reaction occurs appreciably only in a thin layer⁹ on the outside of the reacting solution then convenient equations, equations 18c and 18t, can be derived for calculating the photochemical specific rate constant. Since at the temperatures and light intensities of these experiments the thermal isomerization has any relative importance only in the most deeply colored solutions, that approxi-

(9) A fuller discussion of this treatment as well as of a number of other aspects of this research can be found in a thesis entitled, "The Kinetics of the Photochemical Isomerization of Dichloroethylene Catalyzed by Iodine," submitted to the George Washington University in 1948 by Richard Fisher Wallis.

mation should be good where there is an appreciable thermal effect. Where there is no appreciable thermal effect expressions 18c and 18t for the photochemical specific rate constant reduce to just the forms that would follow from equation 17 without using the thin-layer assumption. Therefore, equations 18 may be used on all of the experiments with deep-colored solutions. In these equations, k_p is the photochemical specific rate constant in deep-colored solutions, k_T is the thermal specific rate constant (called k_1 by Wood and Dickinson^{4c}). Values for k_T to use in equations 18 were calculated from the data of Wood and Dickinson.

$$k_p = -\sqrt{\frac{I_2}{I_0}} \left\{ \left[\frac{K}{t(K+1)} \ln \frac{(K+1)\alpha - 1}{K} \right] - k_T \sqrt{I_2} \right\} \quad (18c)$$

$$k_p = -\sqrt{\frac{I_2}{I_0}} \left\{ \left[\frac{K}{t(K+1)} \ln [1 - (K+1)\alpha] \right] - k_T \sqrt{I_2} \right\} \quad (18t)$$

Equation 18c applies to experiments in which the initial dichloroethylene is all *cis* and equation 18t to those in which it is all *trans*. Available data and the fact the polychromatic light was used do not permit a simple calculation of the numerical value to be expected for the ratio of the pale-solution photochemical specific rate constant, k_p , to the deep-colored-solution photochemical specific rate constant, k_p .

Results and Conclusions

The data and calculated k_p 's for the pale-solution experiments are presented in Tables I and II. In Fig. 5 these k_p 's (except those for the experiments to which footnotes a, b, and d of Table I refer) have been plotted against (I_2) . This graph shows that at a given temperature the k_p 's decrease by only about 10% with a tenfold increase in (I_2) . Both the comparative constancy of the k_p 's and the direction of their change with change in iodine concentration are, in the light of the preceding derivations, compatible with the proposed mechanism. It is to be noted that the light intensities as well as concentrations differed among the experiments the results of which are plotted. Table VII presents the data and calculated k_p 's for the experiments with deep-colored solutions. Again, the comparative constancy of the k_p 's with an eight-fold variation in (I_2) is compatible with the proposed mechanism.

The numbers of the runs tabulated in Tables I, II and III indicate chronological order of the experiments. All of the isomerization experiments carried out except blanks and the preliminary experiments are included in these tables. It can be seen that the second, third and fourth runs gave low k_p 's. In these three cases the reaction cell had been rinsed with solvent but had not been cleaned with chromic acid before filling. In the first run and in all runs after the fourth a

TABLE I
RATE MEASUREMENTS AT 120.6° WITH DILUTE IODINE SOLUTIONS

Run	Mole % total $C_2H_2Cl_2$, $I_2 \times 10^4$	Mole fraction	Duration, hours	Dielect. constant at end	Fraction <i>cis</i> in $C_2H_2Cl_2$ at end	Light intensity, arb. units	k_p , arb. units
1-C	8.09	1.150	5.50	2.579	0.864	5.07	1.44
2-T ^a	9.33	0.410	5.50	2.345	.196	5.08	1.08
3-T ^a	8.06	1.168	5.50	2.371	.296	5.15	1.06
4-C ^a	9.01	0.593	5.50	2.636	.915	5.20	1.05
5-C	8.05	1.173	5.50	2.575	.858	5.23	1.48
6-T	9.04	0.576	5.50	2.386	.302	5.05	1.56
7-C	9.06	.567	5.50	2.626	.886	5.03	1.60
8-T	9.61	.231	5.50	2.352	.209	5.08	1.56
9-T	9.82	.110	6.00	2.337	.171	5.10	1.62
10-C ^b	7.33	1.01	6.00	2.545	.852	4.94	1.60
15-C ^b	7.51	0.74	5.50	2.560	.874	5.07	1.59
16-T	9.50	.302	5.50	2.366	.244	5.08	1.63
17-T	9.12	.542	6.50	2.342	.194	1.36	1.50
18-T	9.13	.525	6.00	2.354	.222	2.05	1.60
19-T	9.44	.337	6.50	2.348	.203	2.13	1.62
20-C	8.25	1.049	7.00	2.601	.904	1.24	1.48
29-C ^d	9.05	0.571	5.50	2.653	.954	5.12	0.54
30-T ^d	9.03	.585	5.50	2.326	.156	5.12	0.69
31-C ^d	9.05	.575	5.25	2.626	.888	4.65	1.67
32-C ^d	9.04	.573	5.50	2.632	.902	4.96	1.30
33-C ^d	9.05	.572	5.50	2.628	.893	5.03	1.47
34-T ^d	9.82	.106	5.00	2.320	.132	4.90	1.52
35-T ^d	9.62	.228	5.00	2.338	.177	5.21	1.40
36-C ^d	8.10	1.144	5.00	2.585	.877	5.00	1.37

Initial isomer indicated by C (for *cis*) or T (for *trans*) following run number. ^a Cell not cleaned with chromic acid before run. ^b Reaction mixture boiled, then frozen, and cell evacuated before sealing off. ^d "Wall" surface tripled by putting glass capillary tubes in reaction cell.

TABLE II
RATE MEASUREMENTS AT 100.0 AND 110.3° WITH DILUTE IODINE SOLUTIONS

Run	Mole % total $C_2H_2Cl_2$, $I_2 \times 10^4$	Mole fraction	Duration, hours	Dielect. constant at end	Fraction <i>cis</i> in $C_2H_2Cl_2$ at end	Light intensity, arb. units	k_p , arb. units
21-C	8.30	1.020	6.00	2.601	0.899	5.20	0.92
22-T	9.04	0.589	6.00	2.356	.229	5.45	0.93
23-C	9.64	.217	7.25	2.667	.929	5.23	1.06
24-T	9.82	.108	7.00	2.318	.128	5.13	0.98
25-T	9.07	.557	6.00	2.335	.178	5.11	.70
26-C	8.28	1.036	7.25	2.605	.912	5.16	.64
27-T	9.62	0.234	7.50	2.320	.135	5.11	.64
28-T	9.83	0.102	8.00	2.311	.112	5.11	.74

Runs 21-C to 24-T inclusive at 110.3°. Runs 25-T to 28-T inclusive at 100.0°.

TABLE III
RATE MEASUREMENTS AT 120.6° WITH CONCENTRATED IODINE SOLUTIONS

Run	Mole % total $C_2H_2Cl_2$, $I_2 \times 10^3$	Mole fraction	Duration, hours	Dielect. constant at end	Fraction <i>cis</i> in $C_2H_2Cl_2$ at end	Light intensity, arb. units	k_p , arb. units
11-T	9.96	3.15	5.00	2.436	0.387	5.10	0.00101
12-C	9.98	1.93	5.50	2.635	.825	5.08	.00098
13-C	9.92	8.10	5.50	2.659	.885	5.05	.00106
14-T	9.85	16.2	5.50	2.365	.233	4.91	.00103

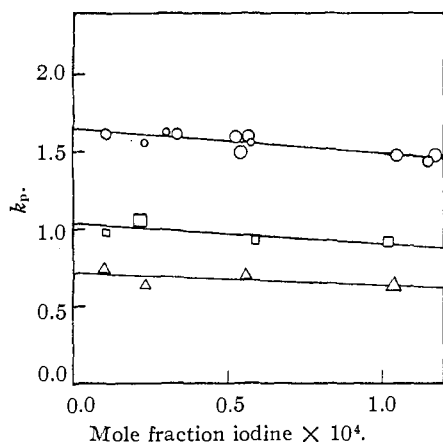

Fig. 5.—Variation of rate constants with iodine concentration for pale solutions: O, 120.6° ; □, 110.3° ; △, 100.0° .

soaking with chromic acid was part of the preparation of the cell.

Two other runs gave markedly low values of k_p , namely, runs 29 and 30 which are the first two of a series of eight in which the glass surface in contact with the reaction solution was approximately tripled by putting thin-walled glass tubing (melting-point tubes) into the solution space in the reaction vessel. This series of experiments was to test the homogeneity of the reaction, a test that seemed especially appropriate in view of the three anomalous results, mentioned in the preceding paragraph, which were obtained when the reaction vessel had not been vigorously cleaned. It seems most probable that the anomalous values obtained in runs 29 and 30 (as compared to all the other k_p 's in Table I and particularly as compared to the values from runs 31 through 36) like the k_p 's from runs 2, 3 and 4, involve faulty manipulation and are invalid. It is difficult to clean, rinse and dry thoroughly a set of capillary tubes entrapped and largely immobilized in a small reaction vessel such as we used. The only difference in technique between the earlier and later runs of the series 29 through 36 was in the care and extent of these operations. We did not feel justified in omitting runs 2, 3, 4, 29 and 30 from the tables because the probability of their invalidity is based on *a posteriori* considerations. But assuming them to be invalid, the agreement of the k_p 's from runs 31 through 36 with the other k_p 's in Table I is evidence that the reaction studied is homogeneous. It is not strange that the average value of k_p in the experiments with capillary tubes should be a little different from the others. It is perhaps remarkable that it is so nearly the same since no correction was attempted for the disturbing effect that the capillary tubing would have on stirring processes and on the optical system.

Only two experiments remain to be mentioned specifically, runs 10 and 15. These were carried out to show that rigorous exclusion of

oxygen had no appreciable effect on the rate of isomerization. In these experiments a solution of *cis*-dichloroethylene and iodine in benzene was put into the reaction vessel, part of the solution was boiled off, the remainder was frozen while being pumped on by a vacuum pump, and then the system was sealed off. The mixture was melted and part of the solution was poured into a side arm which was then sealed off, the rest of the solution in the sealed-off reaction cell being used in the isomerization run. The solution in the side arm was analyzed colorimetrically and by a dielectric constant measurement to determine the initial iodine and dichloroethylene concentrations in the reaction cell.

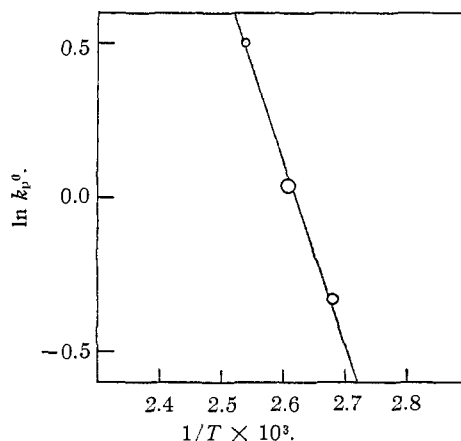

Fig. 6.—Temperature dependence of rate constants for pale iodine solutions.

In Fig. 6 $\ln k_p^0$ is plotted against $1/T$. k_p^0 is the experimental value of k_p at the temperature in question extrapolated (Fig. 5) to zero iodine concentration. From the slope of this curve and a consideration of probable experimental errors the Arrhenius activation energy Q_p of the photochemical iodine-sensitized isomerization can be estimated as $Q_p = 11,900 \pm 700$ cal. mole⁻¹ ($d \ln k_p^0 / dT = Q_p / RT^2$). Wood and Dickinson^{4c} give 31,200 cal. mole⁻¹ as the corresponding activation energy for the thermal iodine-catalyzed isomerization. The difference between these two quantities should be half the heat of dissociation of molecular iodine in these solutions. The difference is 19,300 cal. mole⁻¹. This is in good agreement with the value of 19,400 calculated by Dickinson and Lotzkar^{4b} from the cinnamic acid isomerization data. Half the heat of dissociation of gaseous iodine, 18,100 cal. mole⁻¹ calculated^{4b} from spectroscopic data may also be compared. The similarity of this last figure to the 19,300 calculated from the thermal and photochemical rate experiments would seem to constitute evidence favoring an atom catalysis as distinguished from some other mechanisms which might be proposed and which would be compatible with the other experimental

facts. Other evidence against the ion catalysis possibility is mentioned by Wood and Dickinson.

Summary

The photochemical iodine-sensitized *cis-trans* isomerization of dichloroethylene in benzene solutions has been studied. Isomerization rates have been measured for various light intensities, iodine concentrations, temperatures, and area of

glass surface in contact with the solution. The results indicate that the reaction is homogeneous under the experimental conditions and that a mechanism involving catalysis of the isomerization by iodine atoms is probable.

A value for the activation energy of this photochemical reaction has been calculated from the results of these experiments.

RECEIVED OCTOBER 26, 1948

[CONTRIBUTION FROM THE DEPARTMENT OF CHEMISTRY AND CHEMICAL ENGINEERING OF THE UNIVERSITY OF PENNSYLVANIA]

Effect of Structure on Reactivity.¹ II. Influence of Solvents on Ammonolysis of Esters

BY MAXWELL GORDON,² JOHN G. MILLER AND ALLAN R. DAY

In the first investigation of this series³ the electron release effects of alkyl and aryl groups in the ammonolysis of esters were studied. All of the reaction media employed contained about 18% water because it had been found that most esters will not react appreciably with ammonia in anhydrous dioxane or methanol over a period of several weeks at room temperature. The question of the effect of water on the ammonolysis of esters is subject to more difference of opinion⁴ than any other phase of this work. On the basis of the references cited,⁴ the work in this paper probably offers the first general method for the ammonolysis of esters in the absence of water.

From the earlier investigations and from the work in this laboratory, it may be stated that in general simple esters will not react with ammonia at a useful rate in anhydrous media. The notable effect of water on the rate of ammonolysis suggested that the use of hydroxylated organic solvents might also promote the ammonolysis of esters. Investigation of a series of such solvents has shown this assumption to be correct. Certain of the glycols and related compounds were found to be more effective than water. Furthermore, the results show the same qualitative structure-reactivity correlations as those reported in the first paper³ for aqueous solutions.

Experimental

The experimental method employed for ammonolysis in this investigation was identical with

(1) From a thesis submitted in December, 1947, by M. Gordon to the Department of Chemistry and Chemical Engineering of the University of Pennsylvania in partial fulfillment of the requirements for the degree of Doctor of Philosophy.

(2) National Institute of Health Predoctoral Research Fellow, 1946-1948.

(3) Gordon, Miller and Day, *THIS JOURNAL*, **70**, 1946 (1948).

(4) Fischer and Dilthey, *Ber.*, **35**, 844 (1902); McKenzie and Wren, *J. Chem. Soc.*, 311 (1908); Morrell, *ibid.*, 2701 (1914); Blair, *THIS JOURNAL*, **48**, 37 (1926); Grant and Hinshelwood, *J. Chem. Soc.*, 1351 (1933); Hughes and Ingold, *ibid.*, 252 (1935); Haworth, Haslop, Salt and Smith, *ibid.*, 222 (1944).

that used in the first paper of this series.³ At this point in the work it became apparent that the choice of dioxane as a diluent was particularly fortunate, since it was found that ammonolysis proceeds more slowly in dioxane than in any other solvent tested. On this account dioxane could reasonably be used as a diluent in evaluating the catalytic effects of other solvents.

In addition to the compounds used in the previous work,³ the following were employed: ethylene glycol, b.p. 72° at 1 mm., *n*_D²⁰ 1.4316; diethylene glycol, 101° at 1 mm., 1.4472 at 20°; trimethylene glycol, 88° at 1 mm., 1.4398 at 20°; ethylene glycol monomethyl ether, 43° at 20 mm., 1.4074 at 20°; diethylene glycol monomethyl ether, 68° at 1 mm., 1.4264 at 27°; glycerol, 1.4729 at 20°; propylene glycol, 65° at 1 mm., 1.4293 at 27°; ethylene glycol monoacetate, 61° at 1 mm., 1.4278 at 20°; 1,3-butane-diol, 74° at 0.5 mm., 1.4410 at 20°; isobutylene glycol, 58° at 1 mm., 1.4350 at 20°. The anhydrous ammonia used was controlled with a steel needle valve and metered by means of a bubble counter.

Results

The promoting effect of water on the ammonolysis of ethyl acetate was found to be dependent on its concentration. Thus with no water present there was no measurable ammonolysis in 400 hours, with 5 moles of water/l. the rate constant was 0.000220 l. mole⁻¹ hour⁻¹, with 10 moles of water/l., 0.000450, and with 20 moles of water/l., 0.000750. The concentration of ammonia was 0.809-1.172 moles/l. The lack of ammonolysis in the anhydrous diluent (dioxane) is notable. Further preliminary measurements revealed that other solvents similarly showed an increase in rate of ammonolysis beyond the point where the ammonia-catalyst ratio is 1:1. Other solvents tried were methanol, *t*-butanol, ethylene glycol and glycerol.

Because of the striking effects of the various